

Convotherm maxx pro easyTouch Marine

- 6.10
- 6+1 Shelves GN 1/1 with locking bar
- Electric
- Injection/Spritzer
- Disappearing door



Key features

- Natural Smart Climate™ (ACS+) with extra functions:
 - Crisp&Tasty – 5 moisture-removal settings
 - BakePro – 5 levels of traditional baking
 - HumidityPro – 5 humidity settings
 - Controllable fan – 5 speed settings
- easyTouch 10" TFT HiRes glass touch display (capacitive)
- ConvoClean+ fully automatic cleaning system with eco, regular and express modes – with optional single-dose dispensing
- HygieniCare
- WiFi and Ethernet interface (LAN)
- USB port integrated in the control panel
- TriColor indicator ring – indicates the current operating status
- Steam generated by injecting water into the oven cavity
- LED lighting in the oven cavity
- Disappearing door with triple glazing and with door latch: more space and greater safety at work (available optionally at an additional charge)
- Standard unit feet for bolting or welding (marine feet)

Standard features

- Cooking methods:
 - Steam (30-130°C) with guaranteed steam saturation
 - Combi-steam (30-250 °C) with automatic moisture control
 - Convection (30-250 °C) with optimized heat transfer
- Operation of easyTouch user interface:
 - 10" TFT HiRes glass touch display (capacitive)
 - Smooth-action, quick-reacting scrolling function
 - Natural Smart Climate™ (ACS+)
- Climate Management
 - Natural Smart Climate™ (ACS+), HumidityPro, Crisp&Tasty
- Quality Management
 - Airflow Management, BakePro, Multi-point core temperature probe, Preheat and cool down function
- Production Management
 - Automatic cooking with Press&Go with up to 399 profiles
 - Integrated cookbook with 7 different categories
 - TrayTimer – load management for different products at the same time (manual mode)
 - TrayView – Load management for automatic cooking of different products using Press&Go
 - Favorites management
 - HACCP data storage
 - USB port
 - ecoCooking – energy-save function
 - LT cooking (low-temperature cooking) / Delta-T cooking
 - Cook&Hold – cook and hold in one process
 - Auto Start
 - Regenerate+ – flexible multi-mode rethermalization function with preselect

Standard features

- Cleaning Management:
 - Convoclean+: Fully automatic cleaning system
 - Quick access to individually created and saved cleaning profiles
 - Cleaning Scheduler
 - FilterCare Interface
- HygieniCare:
 - Hygienic Steam Function
 - Hygienic Handles
 - SteamDisinfect
- Design:
 - Unit door with triple glazing, safety latch, sure-shut function, venting position, LEDs for oven cavity lighting and door latch
 - Standard feet with additional bracket for screwing or welding to the supporting surface
 - Steam generated by injecting water into the oven cavity
 - Adjustable appliance feet, from 100 mm to 125 mm
 - Multi-point core temperature probe
 - Integrated recoil hand shower



Convotherm maxx pro
easyTouch Marine

- 6.10
- 6+1 Shelves GN 1/1 with locking bar
- Electric
- Injection/Spritzer
- Disappearing door



Key features

- Natural Smart Climate™ (ACS+) with extra functions:
 - Crisp&Tasty – 5 moisture-removal settings
 - BakePro – 5 levels of traditional baking
 - HumidityPro – 5 humidity settings
 - Controllable fan – 5 speed settings
- easyTouch 10" TFT HiRes glass touch display (capacitive)
- ConvoClean+ fully automatic cleaning system with eco, regular and express modes – with optional single-dose dispensing
- HygieniCare
- WiFi and Ethernet interface (LAN)
- USB port integrated in the control panel
- TriColor indicator ring – indicates the current operating status
- Steam generated by injecting water into the oven cavity
- LED lighting in the oven cavity
- Disappearing door with triple glazing and with door latch: more space and greater safety at work (available optionally at an additional charge)
- Standard unit feet for bolting or welding (marine feet)

Options

- Disappearing door with door latch – more space and greater safety at work
- Steam and vapour removal – built-in condensation module (on request)
- Available in various voltages
- Sous-vide probe, external connection
- Core temperature probe, external connection

Accessories

- Production Management: kitchenconnect® (WiFi/LAN), network solution from Welbilt for updating and monitoring appliances from anywhere
- Signal tower – external operating-state indicator
- Banquet system (optionally as a package or individually): Plate rack, mobile shelf rack, transport trolley, thermal cover
- Stands in various sizes and designs
- Racks, choice of GN or BM versions with securing rod (BM = standard baking sheet size)
- Stacking kit with maritime flanged feet
- Care products for the ConvoClean+ fully automatic cleaning system (multiple and single-measure dispensing)

Front view

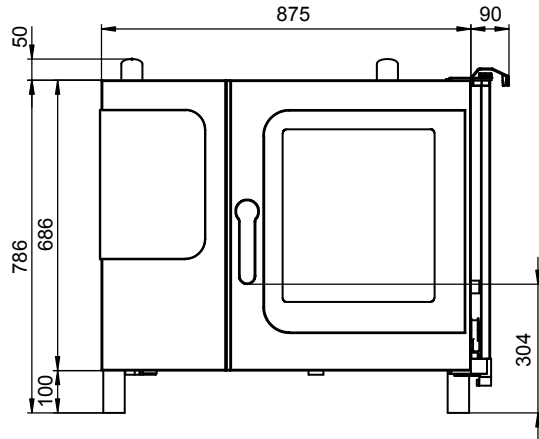

Connection points

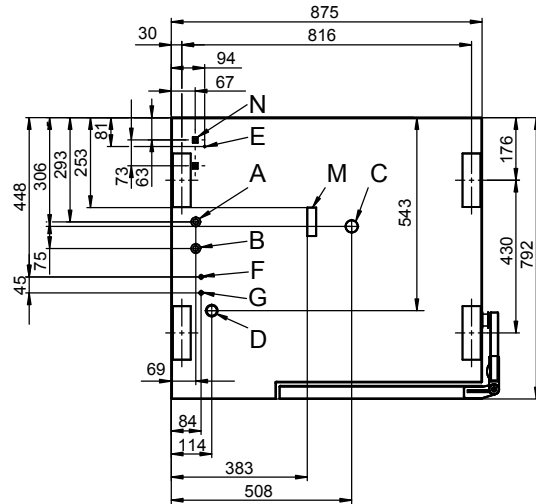

View from above with wall clearances

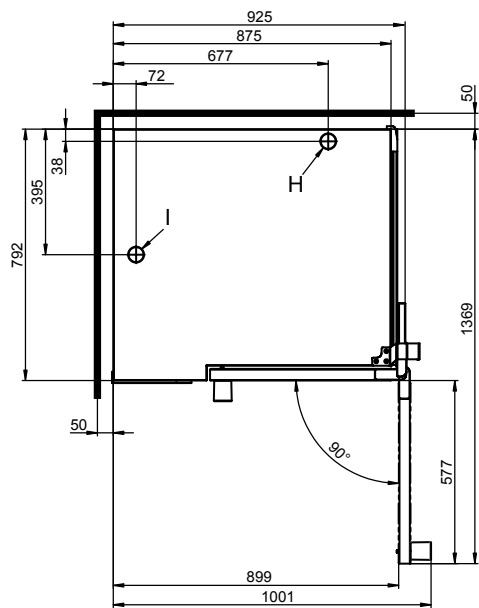

- A Water connection (for water injection)
- B Water connection (for cleaning, recoil hand shower)
- C Drain connection DN 50
- D Electrical connection
- E Equipotential bonding
- F Rinse-aid connection
- G Cleaning-agent connection
- H Air vent Æ 50 mm
- I Dry air intake Æ 50 mm
- M Safety overflow 80 x 25 mm
- N RJ45 Ethernet port

Dimensions and weights

Dimensions including packaging	
Width x Height x Depth	1100 x 1025 x 940 mm
Weight	
Empty weight without options* / accessories	122 kg
Weight of packaging	25 kg
Safety clearances**	
Rear	50 mm
Right-hand side (disappearing door pushed back)	130 mm
Left (see installation instructions)	50 mm
Top***	500 mm

Installation instructions

Absolute tilt of unit in operation*	max. 2° (3.5%)
Clearance from heat sources	min. 500 mm
Recommended clearance for service, left side of unit	min. 500 mm

* Adjustable feet included as standard.

The combi oven must be set up with 3 sides free to provide access for cleaning. As an alternative, use a 150 mm high foot; on request.

* Weight of options 15 kg max.

** Required for functionality of appliance.

*** Depends on type of air ventilation system and nature of ceiling.

Loading capacity

Max. number of food containers	
GN 1/1*	6+1
600 x 400** baking tray	5
Plates max. Ø 32 cm, Ring spacing 65 mm**	20
Plates max. Ø 32 cm, Ring spacing 78 mm**	15
Maximum loading weight	
GN 1/1 / 600 x 400	
Per combi oven	30 kg
Per shelf level	15 kg

* Matching rack included as standard.

** Matching rack available as an accessory.

Electrical supply

3~ 230V 50/60Hz*	
Rated power consumption	10.9 kW
Rated current	27.4 A
Fuse rating	35 A
RCD (GFCI), single-phase frequency converter	Type A/B
Recommended conductor cross-section	4G6
3~ 400V 50/60Hz (also available as 3N~ 400V 50/60Hz)*	
Rated power consumption	11.0 kW
Rated current	15.9 A
Fuse rating	16 A
RCD (GFCI), three-phase frequency converter	Type A/B
Recommended conductor cross-section	5G4
3~ 440V 50/60Hz*	
Rated power consumption	9.2 kW
Rated current	12.1 A
Fuse rating	16 A
RCD (GFCI), three-phase frequency converter	Type B
Recommended conductor cross-section	4G4
3~ 480V 50/60Hz*	
Rated power consumption	10.9 kW
Rated current	13.1 A
Fuse rating	16 A
RCD (GFCI), three-phase frequency converter	Type B
Recommended conductor cross-section	4G4

* Connection to energy optimization system included as standard.

PLEASE NOTE: If the ConvoSmoke option is chosen, the only voltages available are 3~ 230V 50/60Hz and 3N~ 400V 50/60Hz.

Water connection

Water supply	
Water supply*	2 x G 3/4" fixed connection, optionally including connecting pipe (min. DN13 / 1/2")
Flow pressure	150 - 600 kPa (1.5 - 6 bar)
Appliance drain	
Drain version	Funnel drain with P-trap (recommended) or fixed connection
Type	DN 50 (min. internal Ø: 46 mm)
Slope for drain pipe	min. 3.5% (2°)

* Install a backflow preventer approved by the manufacturer if stipulated by the relevant standards and regulations.

Water quality

Water-supply connection A* for water injection	
General requirements	Drinking water, typically soft water (install water treatment system if necessary)
General hardness	4 - 7 °dh / 70 - 125 ppm / 7 - 13 °TH / 5 - 9 °e
Water-supply connection B* for cleaning, recoil hand shower	
General requirements	Drinking water, typically hard water
General hardness	4 - 20 °dh / 70 - 360 ppm / 7 - 35 °TH / 5 - 25 °e
Water-supply connections A, B*	
pH value	6.5 - 8.5
Cl ⁻ (chloride)	max. 60 mg/l
Cl ₂ (free chlorine)	max. 0.2 mg/l
SO ₄ ²⁻ (sulphate)	max. 150 mg/l
Fe (iron)	max. 0.1 mg/l
SiO ₂ (silicate)	max. 13 mg/l
NH ₂ Cl (monochloramine)	max. 0.2 mg/l
Temperature	max. 40 °C
Electrical conductivity	min. 20 µS/cm

* See diagram of connection points, page 2.

Water consumption

Water-supply connection A*	
Ø Consumption for cooking	2.3 l/h
Max. consumption	0.6 l/min
Water-supply connections A, B	
Ø Consumption for cooking**	3.5 l/h
Max. water flow rate	15 l/min

* Values for selecting the capacity of the water treatment system.

** Including water used for cooling the wastewater.

PLEASE NOTE: See diagram of connection points, page 2.

Emissions

Dissipated heat*	
Latent heat	2100 kJ/h / 0.58 kW
Sensible heat	2900 kJ/h / 0.81 kW
Waste water temperature	max. 80 °C
Noise during operation	max. 70 dBA

* The dissipated heat values were measured as per DIN 18873-1 "Methods for measuring the energy use of equipment for commercial kitchens — Part 1". The type and frequency of appliance usage are decisive for the specification of an air conditioning and ventilation system. These values can be higher than the values indicated for dissipated heat. Guide values can be found in the technical literature, e.g. in VDI 2052. Please consult your specialized design engineer for planning an air conditioning and ventilation system.

ACCESSORIES

(Please refer to the Accessories brochure for detailed information)

Stacking kit

Permitted combinations	6.10 on 6.10 6.10 on 10.10
Select "Stacking kit for Convotherm 4 Marine version"	

Please observe the following points:

- This document is to be used solely for planning purposes.
- Please refer to the Installation manual for further technical data and guidance on installation and positioning.

9769372_00_ENG_GBR 05/24, © 2024 Welbilt. Continuous improvements to the product may mean changes to the specification are made without explicit mention.